

XH-21 寸铝底标题 1

XH-21" Industrial Self-Propelled Gas Lawn Mower GXV160 163cc 4-Stroke Aluminum Chassis

标题 2

XH 21" 2-in-1 RWD Self-Propelled Gas Lawn Mower with Honda GXV160 Engine

主图+副图:









Commercial-grade lawn mower, 10-position height adjustment, lightweight aluminum deck, 70L large grass catcher, ideal for residential & commercial lawn care.

技术参数表:

Technical Parameters:

Product Name	21" Aluminum Deck Lawn Mower
Power Model	GXV160-SFC
Engine Type	Single-cylinder, air-cooled, 4-stroke
Walking Type	Push / Self-propelled
Displacement	163cc
Self-propelled Speed Gears	3-speed
Transmission Type	Shaft drive
Rotational Speed	3000r/min±200
Cutting Diameter	530mm/21"
Cutting Height	15-80mm
Handle Height Adjustment	10 gears

Oil Tank Capacity	0.65L
Grass Collection Method	Automatic Grass Collection
Fuel Tank Capacity	1.9L
Grass Collection Capacity	70L
Gross Weight	55.62kg
Net Weight	45.35kg
Packaging Case	Wooden Box
Package Size	92.5×58.5×45cm



High-power Lawn Mower: Engine options: Honda / Loncin / Zongshen / Xinghu

- Check engine oil and fuel before use. Use fresh unleaded gasoline.
- Adjust cutting height (15–80mm) with the 10-position lever.
- Attach the grass bag and clear stones/debris on the lawn.
- Press the safety lever, pull the starter rope to start the engine.

- Squeeze the drive lever to use 3-speed self-propelled function.
- Mow in straight lines; avoid steep slopes over 15°.
- Release the safety lever to stop the engine and blade immediately.
- After mowing, empty the grass bag and clean the mower deck.
- Regularly check the blade, air filter, and engine oil for maintenance.
- Fold the handle for easy storage in a dry, ventilated area.

报关资料表:

Place of Origin	Jinhua, Zhejiang, China	Engine Model	GXV160-SFC
Product Name	Gasoline Lawn Mower	Application	Garden, park, school, lawn mowing
Gross Weight	55.62kg	Color	Silver Gray + Black
Net Weight	45.35kg	Packing Box	Wooden Case
Package Size	92.5×58.5×45cm	Material	Aluminum and Plastic
HS Code	8433110000	Packing Quantity	1 unit/ctn



OHV engine

- Stable
- Durable
- Reliable



Compared with conventional OHV engines, OHV engines feature faster acceleration, higher torque, stronger traction, ideal for lawn mowing applications.

OHV engine:

Stable Durable Reliable Compared with conventional OHV engines, OHV engines feature faster acceleration, higher torque, stronger traction, ideal for lawn mowing applications.

Alloy swinging blade

Anti-obstacle, auto-retract when hitting stones



Cutting Width

53cm

Cutting Height

15-80mm

Alloy swinging blade:

Anti-obstacle, auto-retract when hitting stones Cutting Width 46-53cm Cutting Height 15-80mm

Shaft Drive

Direct shaft connection between self-propelled system and engine



Shaft Drive:

Direct shaft connection between self-propelled system and engine

- Check engine oil and fuel before use. Use fresh unleaded gasoline.
- Adjust cutting height (15–80mm) with the 10-position lever.
- Attach the grass bag and clear stones/debris on the lawn.
- Press the safety lever, pull the starter rope to start the engine.
- Squeeze the drive lever to use 3-speed self-propelled function.
- Mow in straight lines; avoid steep slopes over 15°.
- Release the safety lever to stop the engine and blade immediately.
- After mowing, empty the grass bag and clean the mower deck.
- Regularly check the blade, air filter, and engine oil for maintenance.
- Fold the handle for easy storage in a dry, ventilated area.

3-speed control, effortless operation.

Travel speed (m/s)

3rd gear: 1.4

2nd gear: 1.1

1st gear: 0.8



3-speed control, effortless operation. Travel speed (m/s): 1st gear: 0.8 | 2nd gear: 1.1 | 3rd gear: 1.4

Upgraded 10-position height adjustment

Choose the right setting for different lawn heights to easily trim all kinds of weeds.



15-80mm adjustable cutting height

Upgraded 10-position height adjustment:

Choose the right setting for different lawn heights to easily trim all kinds of weeds. 15-80mm adjustable cutting height

Easy to store

Foldable design

Foldable design, easy to store and carry anywhere.



Easy to store Foldable design:

Foldable & Space-Saving Design

- Foldable handle for compact storage
- Easy to carry and transport
- Ideal for home garden use

Component Analysis:

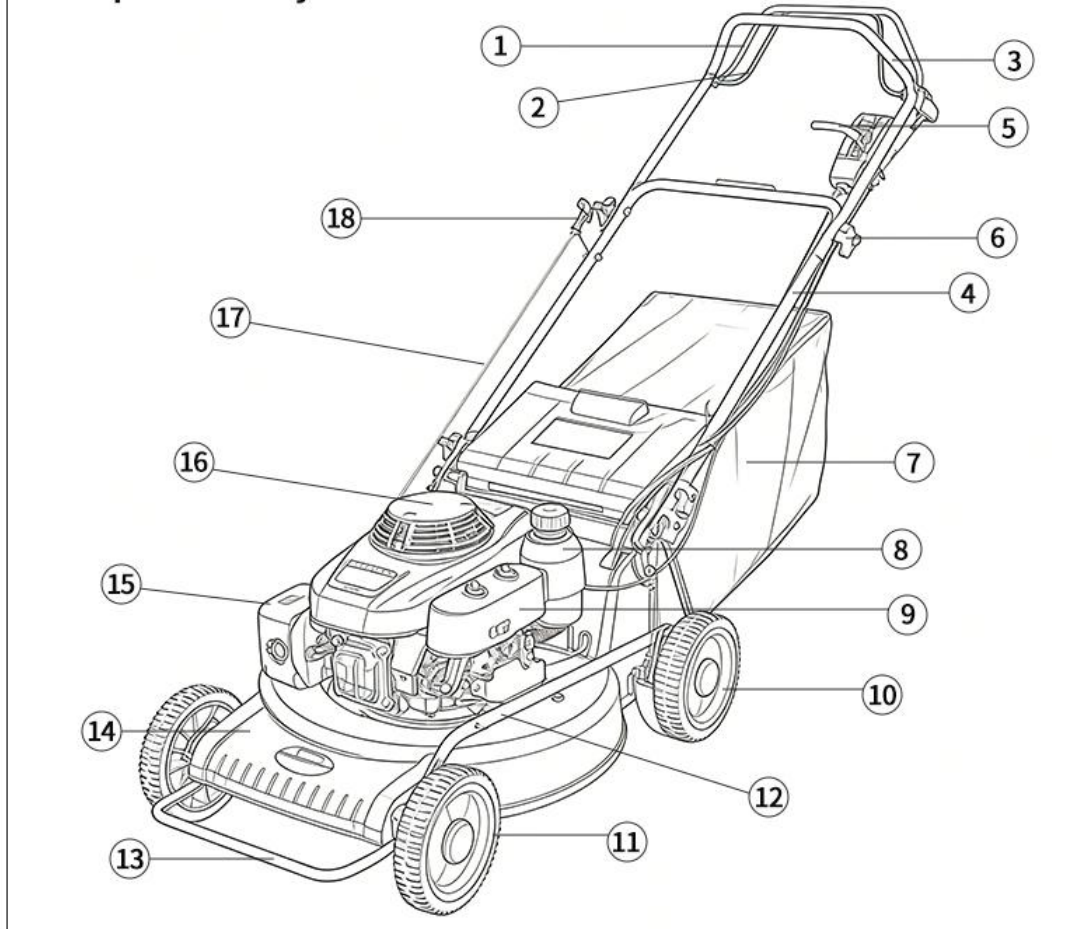

Component Description:

1.Engine Stop Lever	7.Grass Catcher Bag	13.Front Bumper
2.Drive Lever	8.Fuel Tank	14.Aluminum Deck Assembly
3.Upper Handle	9.Air Filter	15.Muffler
4.Lower Handle	10.Self-Propelled Rear Wheel	16.Recoil Starter Pulley
5.Height Adjustment Lever	11.Front Wheel	17.Starter Rope
6.Lock Nut	12.Deck Linkage	18.Starter Handle

- Check engine oil and fuel before use. Use fresh unleaded gasoline.
- Adjust cutting height (15–80mm) with the 10-position lever.
- Attach the grass bag and clear stones/debris on the lawn.
- Press the safety lever, pull the starter rope to start the engine.
- Squeeze the drive lever to use 3-speed self-propelled function.
- Mow in straight lines; avoid steep slopes over 15°.
- Release the safety lever to stop the engine and blade immediately.
- After mowing, empty the grass bag and clean the mower deck.
- Regularly check the blade, air filter, and engine oil for maintenance.
- Fold the handle for easy storage in a dry, ventilated area.



Xinghu Power Machinery Co., Ltd.:

A professional manufacturer of garden machinery with strong production capacity, dedicated to delivering high-quality lawn mowers and power tools to global markets.

Contact Us:

Phone / WeChat / WhatsApp: +86 15268682136

Email: alice@cnxinghu.com

Website: <http://www.cnxinghu.com>

OUR CERTIFICATE

Welcome to our website

ISO

EPA

CE

ASF

EUR05

GSG

WHY CHOOSE US

Welcome to our website

FACTORY
Our company has its own factory, which covers a wide area and has strong production capacity and convenient transportation

PRODUCT QUALITY
Our products have passed the international multi-quality inspection standards

OUR TEAM
Our company has professional production technicians and pre-sales customer service staff

TECHNOLOGY
We use advanced technology and production processes at home and abroad

Fully Certified & Trusted Xinghu Gas Lawn Mowers:
 Backed by ISO, EPA, CE, EUR05 and other global certifications, with strong factory capacity, strict quality control, professional team and advanced technology for reliable garden machinery supply.



Reliable Manufacturing & Supply Chain for Xinghu Gas Lawn Mowers:
From strict factory testing, precision diemaking, full spare parts support to efficient global dispatch, we deliver high-quality

Testing Laboratory

Professional testing laboratory with complete equipment, strict quality control to ensure stable and reliable products.

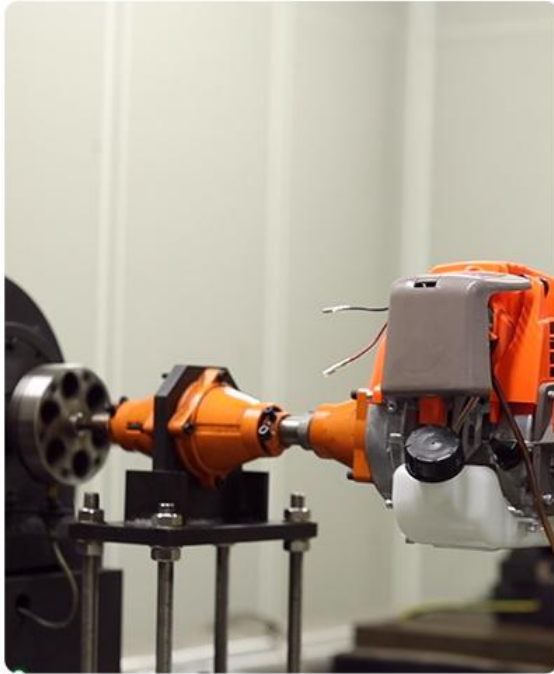

Professional Testing Laboratory:

Equipped with complete testing facilities and strict quality control to guarantee stable, reliable performance for Xinghu gas lawn mowers and garden machinery.



In the Canton Fair



Xinghu at the Canton Fair:

Showcasing premium gas lawn mowers and garden machinery to global buyers, building trusted partnerships for worldwide distribution.

FAQ

Q: Is your 21-inch lawn mower suitable for European markets?

A: Yes, it is widely used in Germany, UK, France, Italy, Spain and other EU countries, matching local Gartenarbeit, Garden Care, Rasenmäher demands.

Q: What certifications do you have?

A: Our gas lawn mowers have CE, EPA, EUR05 certifications, fully compliant with EU and US safety & environmental standards.

Q: Do you accept OEM & ODM orders?

A: Yes, we support customized logo, color, packaging and configuration for global distributors.

Q: What engine do you use?

A: Equipped with reliable 4-stroke engines (Honda, Zongshen, Loncin, Xinghu Power available) for strong power, low fuel consumption, and quiet operation.

Q: Why choose aluminum deck?

A: Aluminum deck is lightweight, rustproof, durable and better for long-term outdoor garden work.

Q: What's your MOQ and delivery time?

A: Low MOQ for trial orders; fast delivery supported by our factory stock and mature logistics.

Q: Do you provide spare parts?

A: Full spare parts are available to ensure stable after-sales service for your market.

Q: Are you a factory or trading company?

A: We are a professional garden machinery manufacturer with 30 years of experience, supporting stable bulk supply.